

CAD FILE:

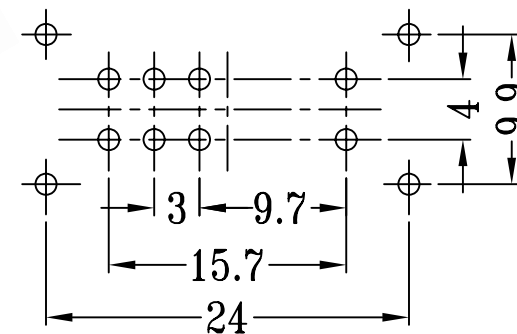
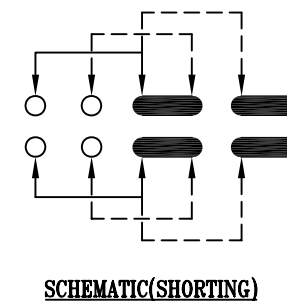
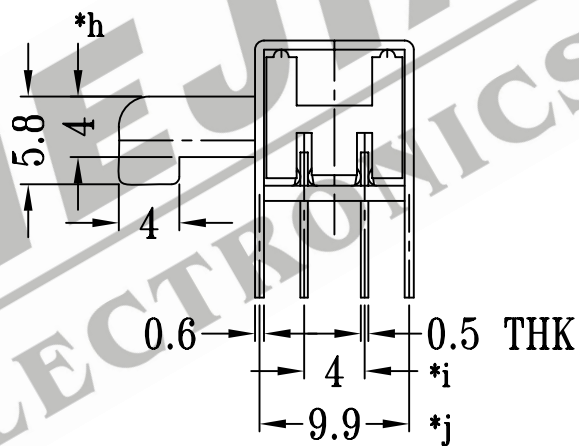
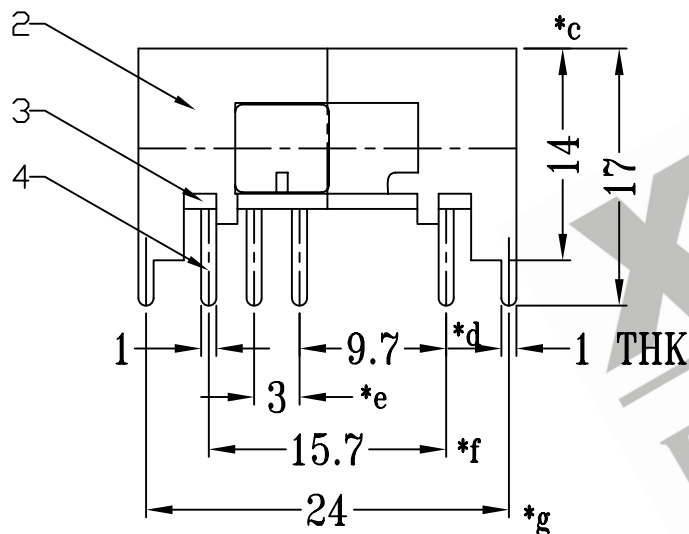
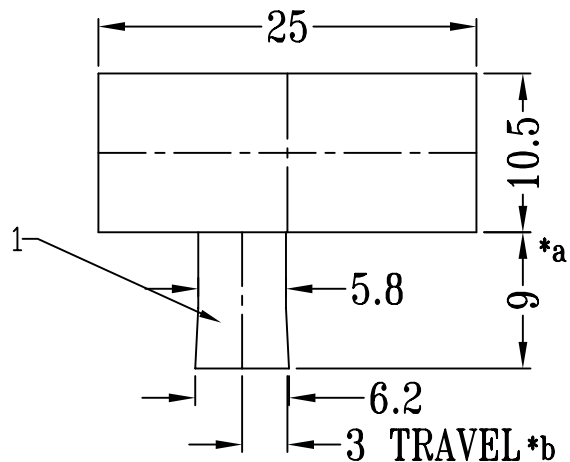

P.C.B LAYOUT

注:带"*"表示关键尺寸(10个)

NO.	PARTS	MATERIALS	Q'TY	FINISH	TOLERANCE UNLESS SPECIFIED	SHENZHEN XIEJIA ELECTRONICS CO.,LTD.				
8						TITLE : HORIZONTAL L SLIDE SWITCH UNIT : mm DRWG NO.: XJ-DR-SK23F01-00				
7	CONTACT CLIP	PBS STRIP	2	Ag PLATED						MODEL: SK-23F01 SCALE: 2:1
6	SPRING	STEEL WIRE	1	TEMPER	WITHIN: 1.5 ±0.1mm	ISSUE	DATE	DESCRIPTIONS OF REVISION		APPD.
5	STEEL BALL	STEEL	1	NATURAL	OVER: 1.5 ±0.2mm			DWN. ZHOUYU 2005-9-6		
4	TERMINAL	BRASS STRIP	8	Ag PLATED OVER Ni PLATED				CHK'D FANGYING 2005-9-6		
3	BASE	PHENOLIC RESIN	1	NATURAL				APPD. KANGXINAN 2005-9-6		
2	FRAME	STEEL STRIP	1	Ni PLATED						
1	KNOB	POM	1	BLACK						
ALL MATERIALS MUST BE COMPLIANT TO ROHS										